

CSE 390B, Winter 2023

Building Academic Success Through Bottom-Up Computing

Annotation Strategies & Hack Assembly

Annotation Strategies, Hack Assembly Memory
Representation, Multiplication Implementation Exercise

Lecture Outline

- ❖ **Strategies for Annotating Texts**
 - **Motivation and Techniques for Annotation**
- ❖ Hack Assembly Memory Representation
 - I/O, Memory Mapping, External vs. Internal Memory
- ❖ Hack Assembly Language Review
 - Registers, A-Instructions, Symbols, & C-Instructions
- ❖ Multiplication Implementation Exercise
 - Multiplying Two Numbers in Hack Assembly

Cornell Note-taking Follow-up Discussion

In groups, discuss the following about the Cornell notes you took from this Tuesday's lecture:

- ❖ What are some of the key points you wrote in your summary?
- ❖ What were some of the questions you came up with?
- ❖ What are you still left feeling confused or uncertain about after Thursday's lecture?

Annotating Your Texts

❖ WHAT

Intentionality of interacting with a text to enhance the reader's understanding of, recall of, and reaction to the text



Annotating Your Texts

❖ WHAT

Intentionality of interacting with a text to enhance the reader's understanding of, recall of, and reaction to the text

❖ HOW

- **Highlighting**, underlining or using [brackets] to note key points or ideas

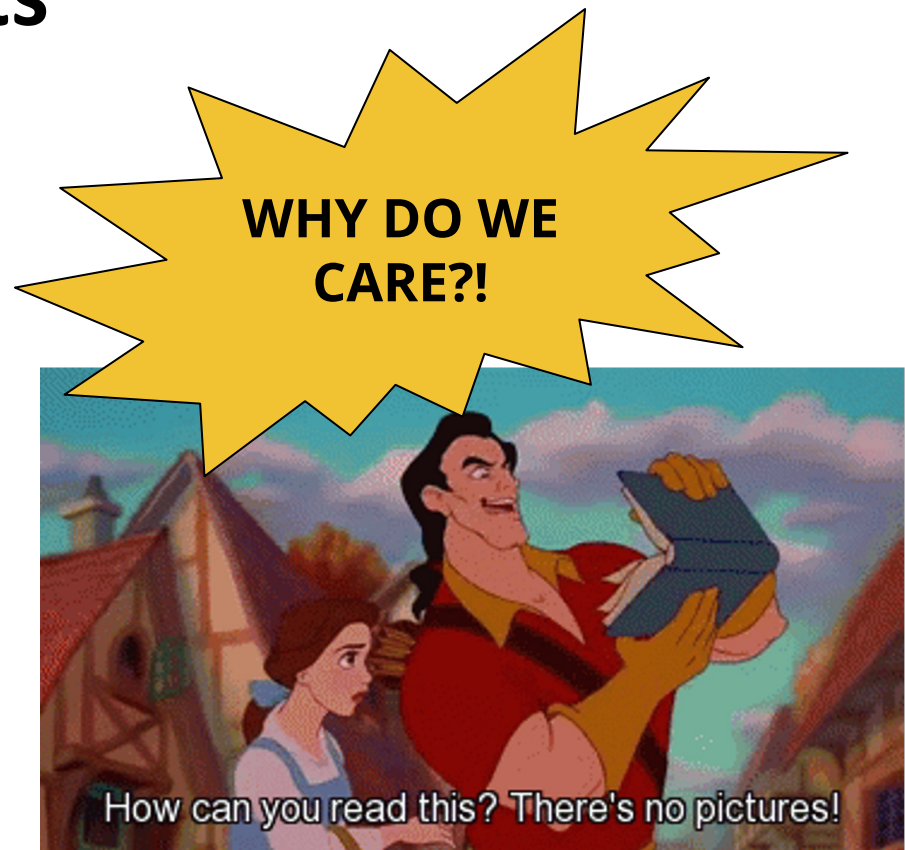

Annotating Your Texts

❖ WHAT

Intentionality of interacting with a text to enhance the reader's understanding of, recall of, and reaction to the text

❖ HOW

- **Highlighting**, underlining or using [brackets] to note key points or ideas
- Circling unfamiliar words or confusing parts of the text



Annotating Your Texts

❖ WHAT

Intentionality of interacting with a text to enhance the reader's understanding of, recall of, and reaction to the text

❖ HOW

- **Highlighting**, underlining or using [brackets] to note key points or ideas
- Circling unfamiliar words or confusing parts of the text
- *Paraphrasing or summarizing passages/chapters/sections*

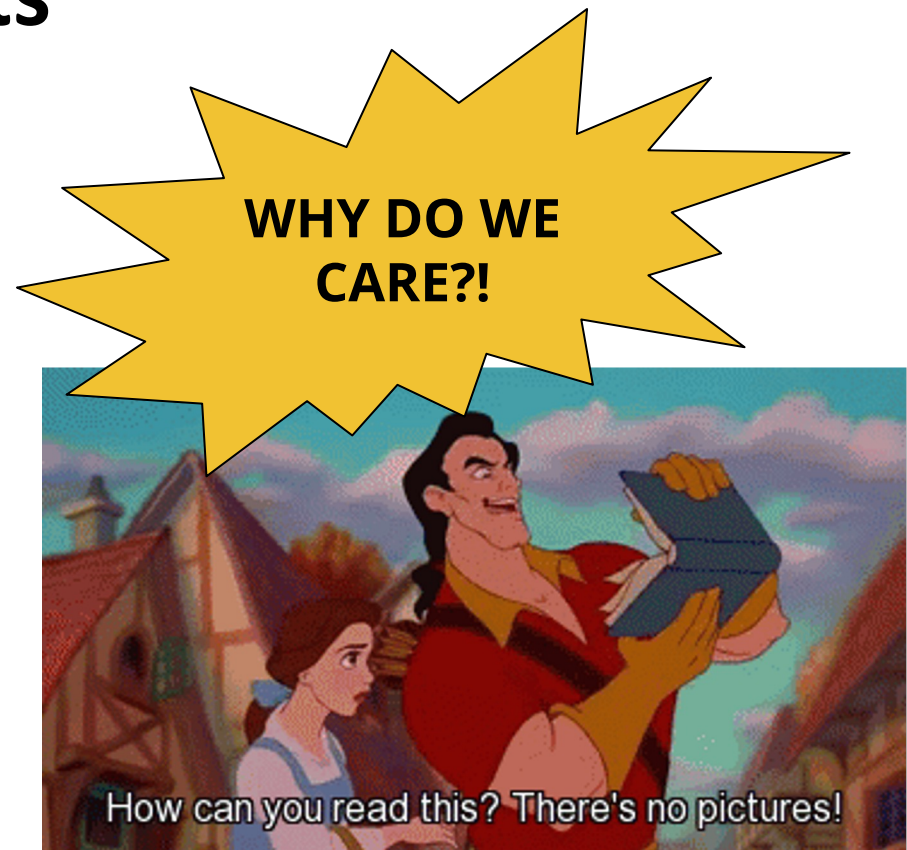

Annotating Your Texts

❖ WHAT

Intentionality of interacting with a text to enhance the reader's understanding of, recall of, and reaction to the text

❖ HOW

- **Highlighting**, underlining or using [brackets] to note key points or ideas
- Circling unfamiliar words or confusing parts of the text
- *Paraphrasing or summarizing passages/chapters/sections*
- *Commenting or reacting to the text* 🤔



Lecture Outline

- ❖ Strategies for Annotating Texts
 - Motivation and Techniques for Annotation
- ❖ **Hack Assembly Memory Representation**
 - **I/O, Memory Mapping, External vs. Internal Memory**
- ❖ Hack Assembly Language Review
 - Registers, A-Instructions, Symbols, & C-Instructions
- ❖ Multiplication Implementation Exercise
 - Multiplying Two Numbers in Hack Assembly

Review: What is Binary?

- ❖ A **base-n** number system is a system of number representation with **n symbols**
- ❖ Decimal system is a base-10 number system
 - Base-10 symbols: 0, 1, 2, 3, 4, 5, 6, 7, 8, 9
 - Increase a number by moving to the next greatest symbol
 - Add another digit when we run out of symbols
- ❖ Binary is a base-2 number system
 - Often prefixed with 0b (e.g., 0b1101, 0b10)
 - Base-2 symbols: 0, 1

Hexadecimal

- ❖ Base-16 number system
 - Symbols: 0, 1, 2, 3, 4, 5, 6, 7, 8, 9, A, B, C, D, E, F
- ❖ Commonly used for referring to memory addresses
 - Simple to convert between binary and hexadecimal
 - Hexadecimal uses fewer digits to represent a value than binary
- ❖ Uses the prefix 0x to indicate a number is written in hexadecimal
 - 32 is decimal, 0x32 is hexadecimal

Number Representation Comparison

Decimal	Hexadecimal	Binary
0	0x0	0b0000
1	0x1	0b0001
2	0x2	0b0010
3	0x3	0b0011
4	0x4	0b0100
5	0x5	0b0101
6	0x6	0b0110
7	0x7	0b0111
8	0x8	0b1000
9	0x9	0b1001
10	0xA	0b1010
11	0xB	0b1011
12	0xC	0b1100
13	0xD	0b1101
14	0xE	0b1110
15	0xF	0b1111

Binary and Hexadecimal Conversion

- ❖ One-to-one correspondence between binary and hexadecimal
- ❖ To convert from binary to hexadecimal, swap out binary bits digits for the corresponding hexadecimal digit (or vice versa)
- ❖ Example: $0x3A$ is $0b0011_1010$
 - $0x3 == 0b0011$
 - $0xA == 0b1010$

Hack Assembly: Input / Output

- ❖ Two memory maps are created for you by underlying hardware
 - **SCREEN** is a huge map where each pixel is one bit
 - **KEYBOARD** is a single 16-bit word map with code of current key

- ❖ Example:

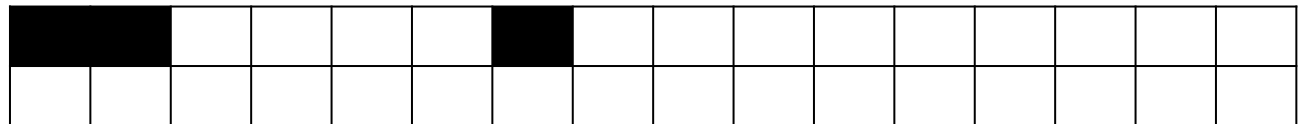
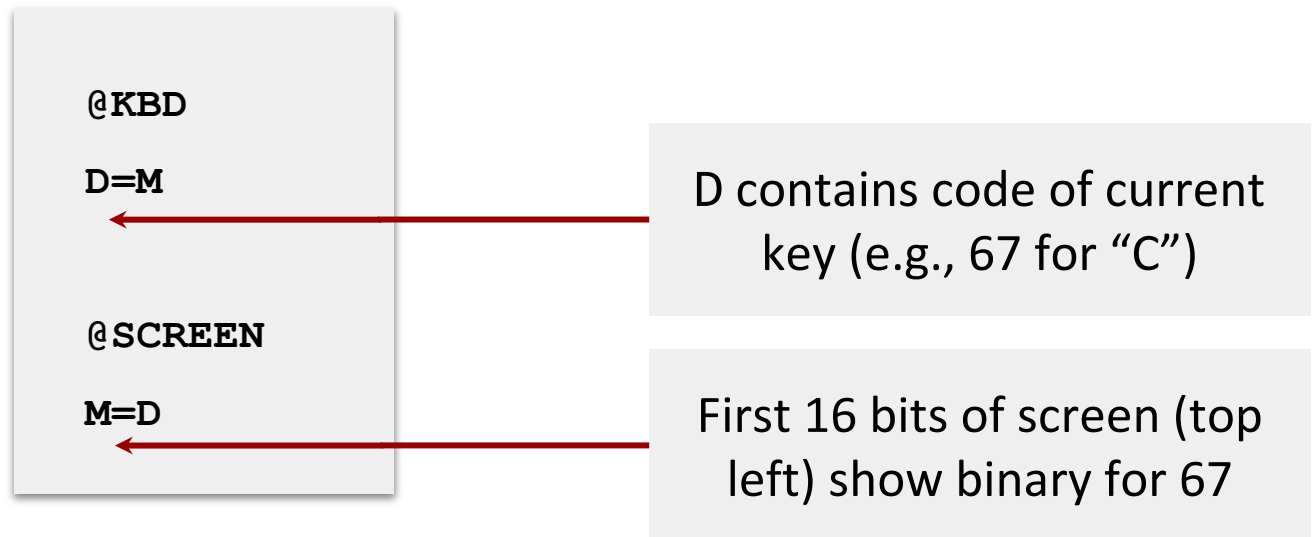

Hack: Input / Output

❖ I/O is memory mapped

- Corresponds to some region of RAM
- Low-level drivers are constantly refreshing

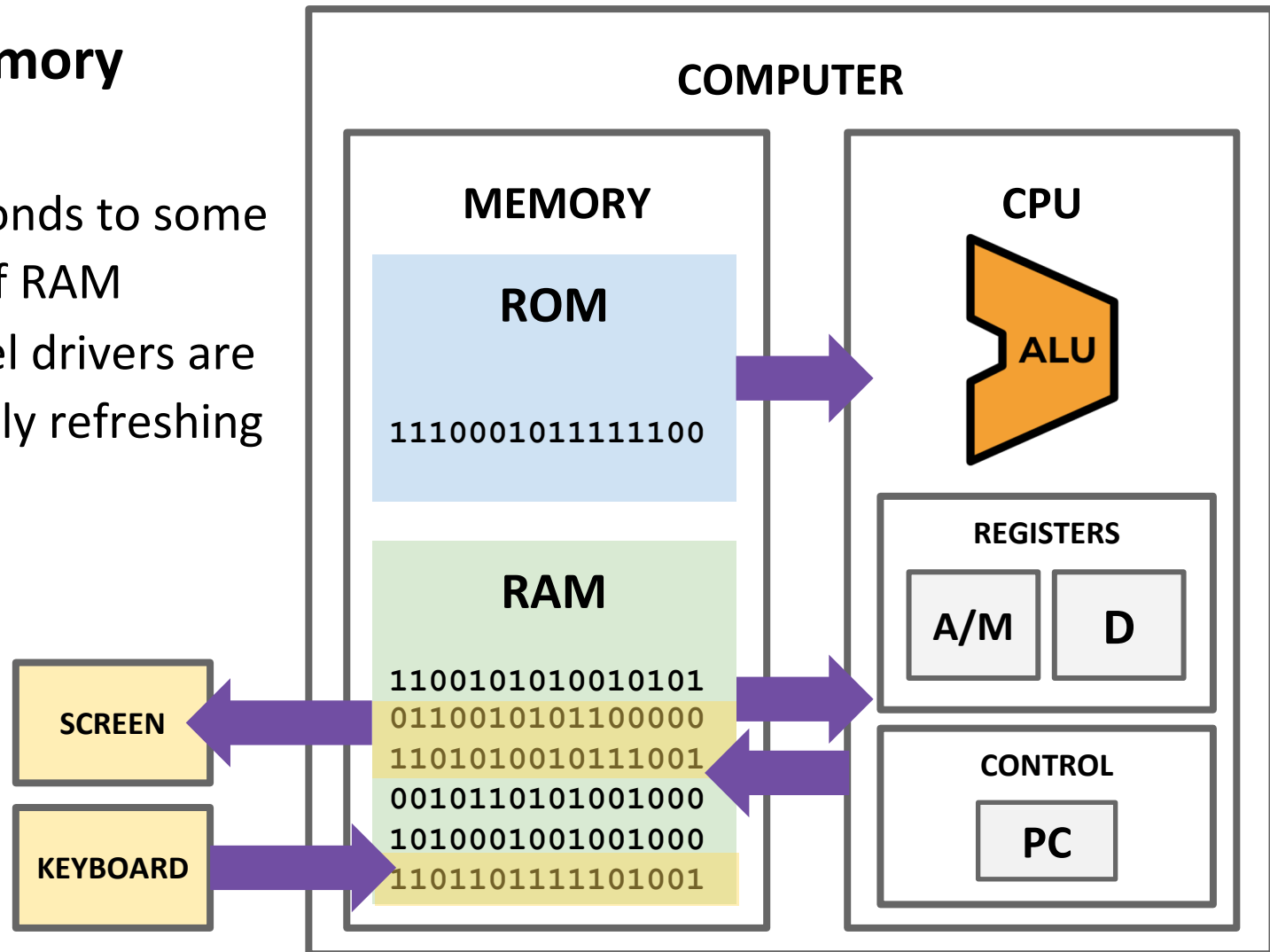

Hack: Memory Mapped Output

- ❖ Each bit of the screen memory map corresponds to one pixel (1 = black, 0 = white)
- ❖ The start of the memory map is accessible via the **SCREEN** symbol in Hack.asm

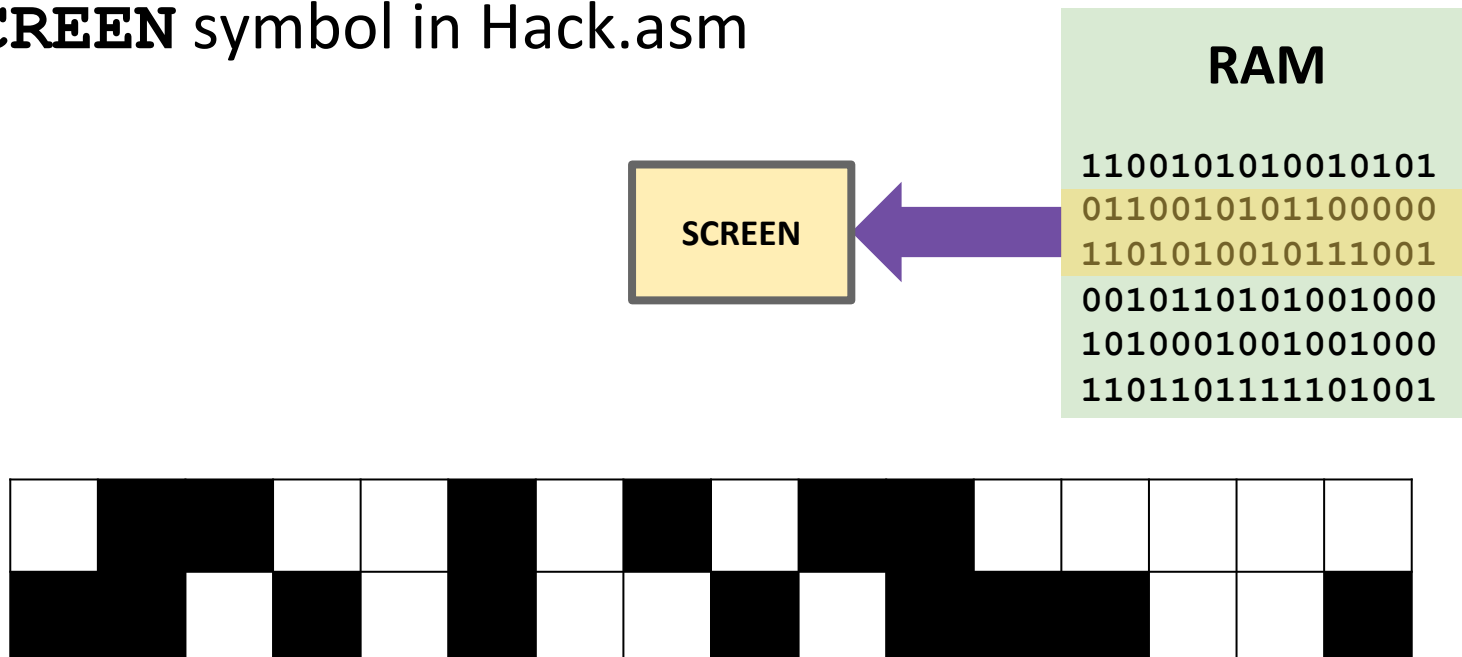

Hack: External Memory Abstraction

- ❖ Programmer sees one **RAM32K** memory region
 - Only 16K + 8K + 1 words are being used
- ❖ Split into three parts: **SCREEN**, **KEYBOARD**, and the rest
 - Screen: 8K words
 - Keyboard: 1 words
 - The rest: 16K words (used for data and instructions)
- ❖ Programmer can use the same interface to interact with the **SCREEN**, **KEYBOARD**, or normal RAM
 - Just specify address, value, and other inputs
 - Address determines what part we are interacting with

Hack: Internal Memory Implementation

- ❖ In reality, separate memory chips for memory devices is unnecessary
 - “Drivers” are code relaying changes in memory values to the device
- ❖ In Hack, it’s not as simple as one **RAM32K** chip
 - Use internal **SCREEN** and **KEYBOARD** chips so our virtual computer can detect and show changes in the screen and keyboard
- ❖ Our memory chip has three subchips: **SCREEN**, **KEYBOARD**, and **RAM16K**
 - Process the address given by the programmer and relay the request to the appropriate subchip

Hack: Memory Abstraction User View

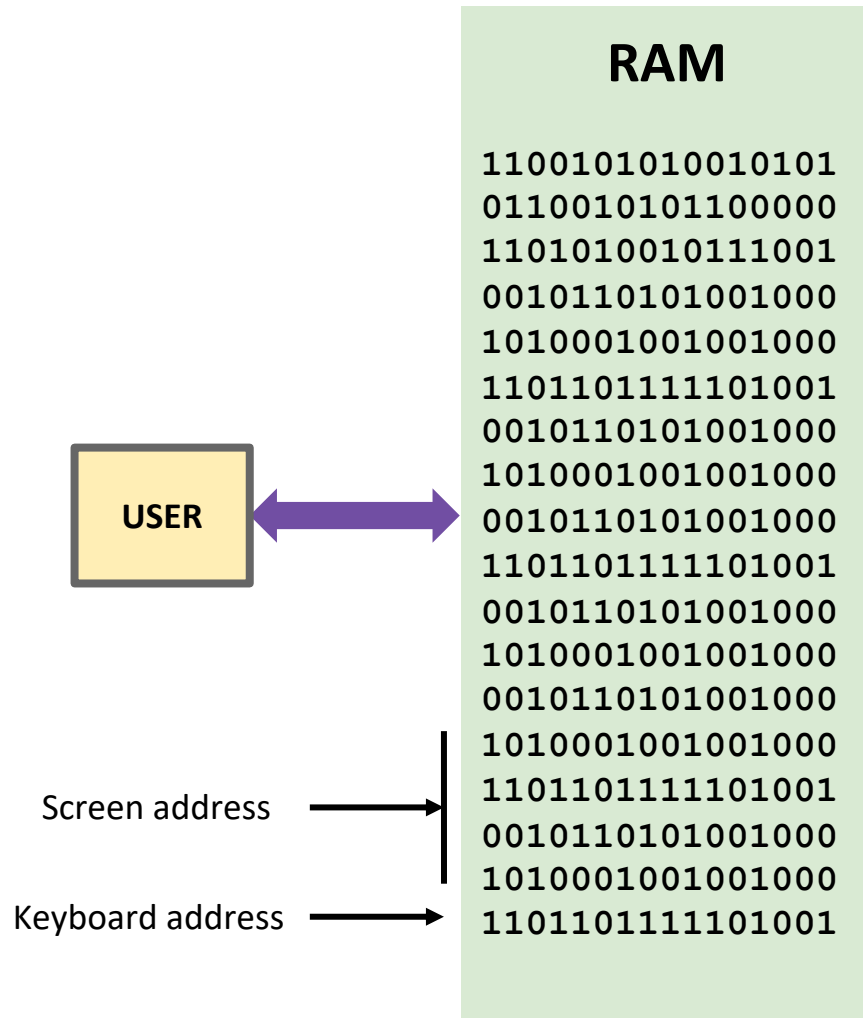

Hack: Memory Abstraction Internal View

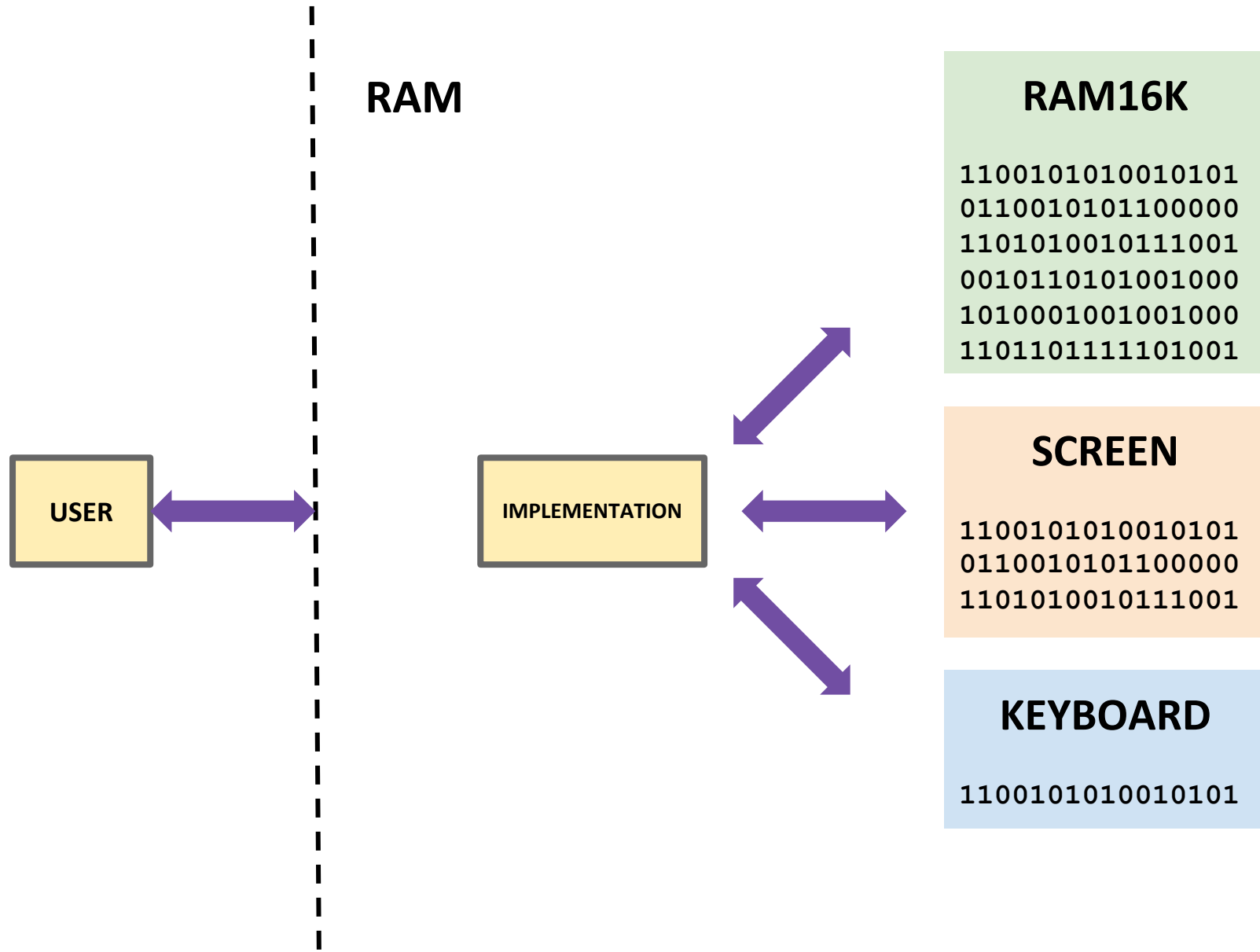

< Lecture 8: Annotation Strategies & Hack Assembly



Loading...



Lecture Outline

- ❖ Strategies for Annotating Texts
 - Motivation and Techniques for Annotation
- ❖ Hack Assembly Memory Representation
 - I/O, Memory Mapping, External vs. Internal Memory
- ❖ **Hack Assembly Language Review**
 - **Registers, A-Instructions, Symbols, & C-Instructions**
- ❖ Multiplication Implementation Exercise
 - Multiplying Two Numbers in Hack Assembly

The Hack Computer

- ❖ The hardware you will build
 - 16-bit word size
 - ROM: sequence of instructions
 - ROM[0], RAM[1]...
 - RAM: data sequence
 - RAM[0], RAM[1]...

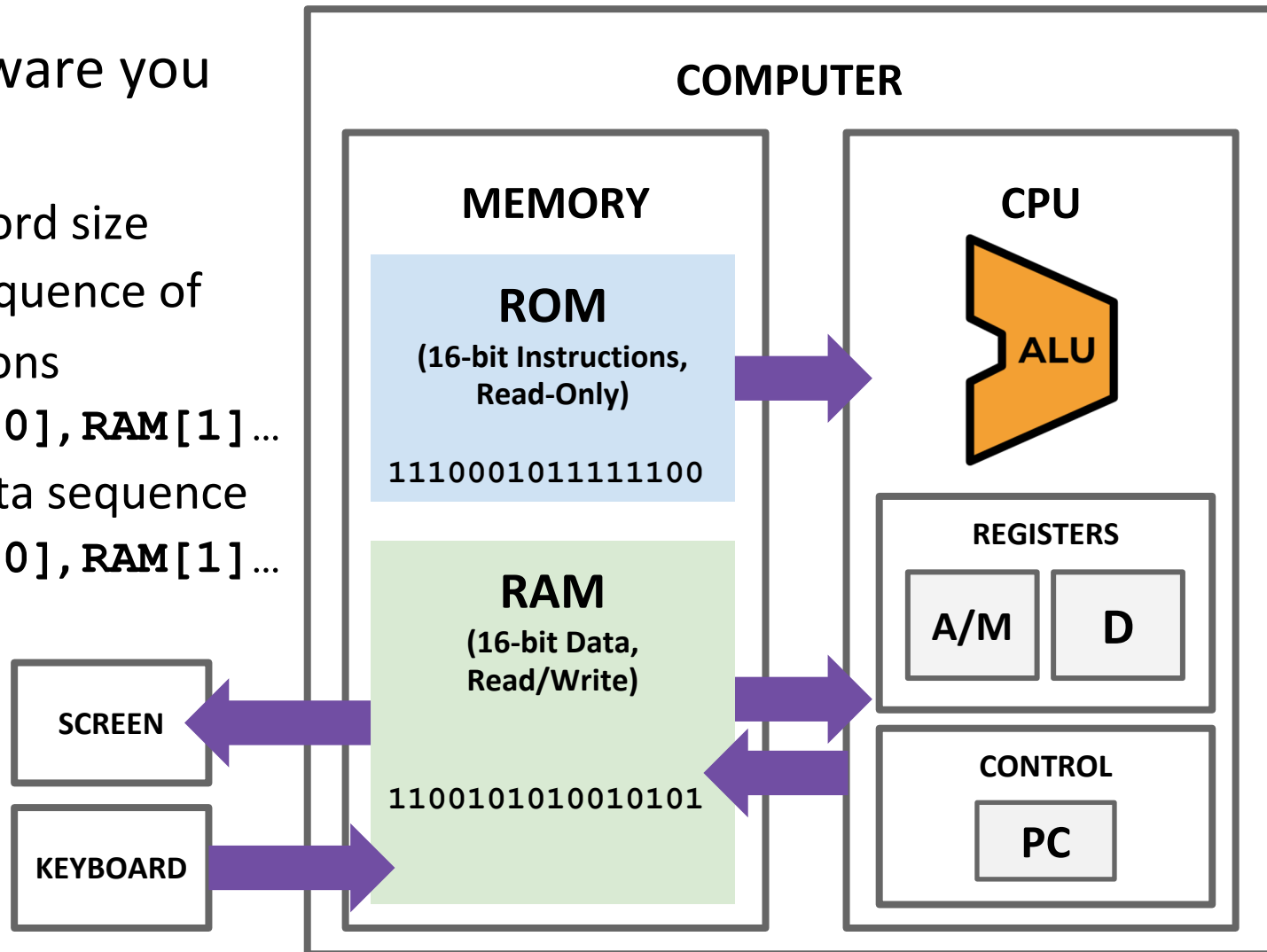

The Hack Machine Language

- ❖ Two types of instructions (16-bit)
 - A-instructions *load data*
 - C-instructions perform *computations*
- ❖ Program: sequence of instructions

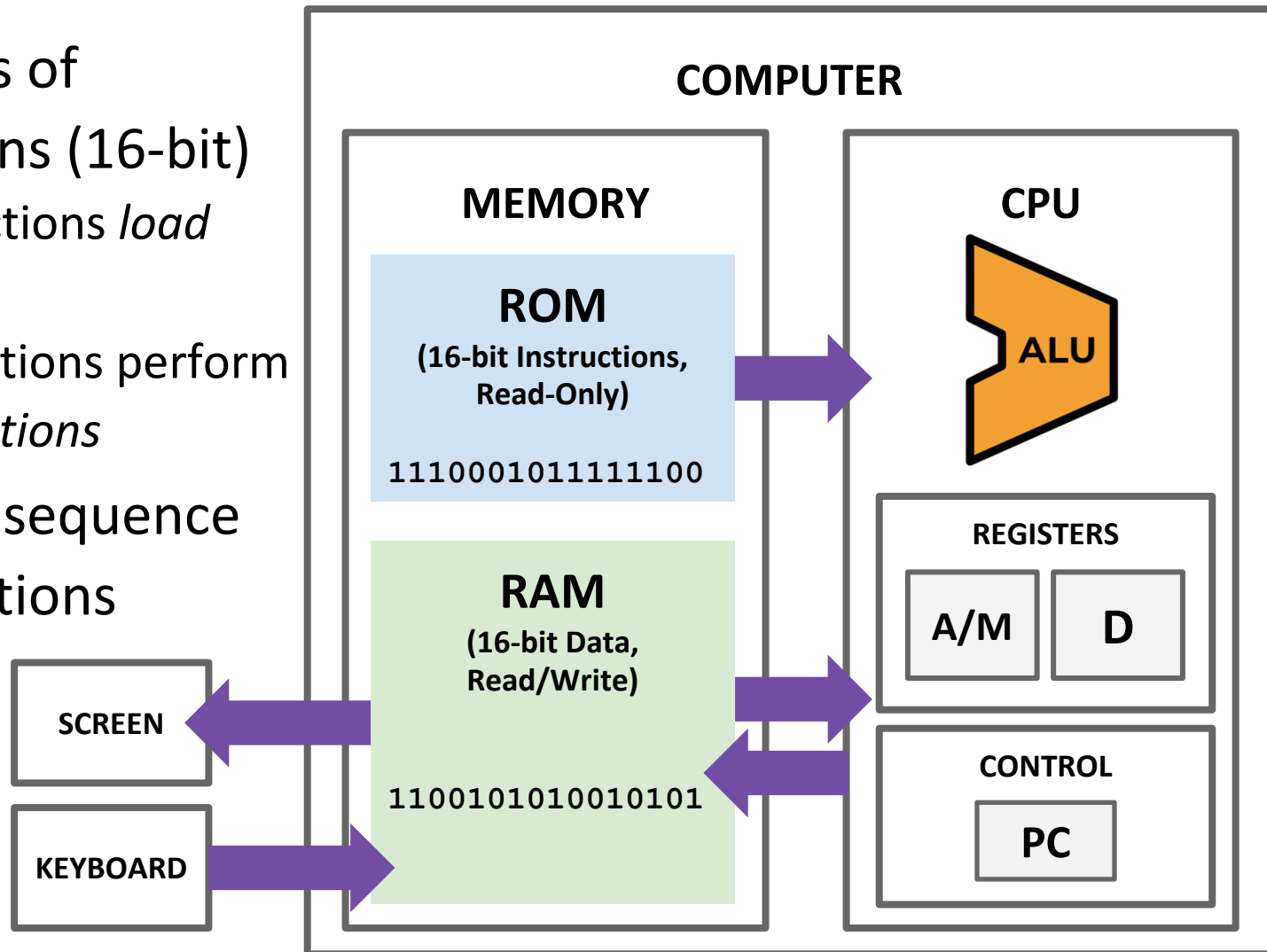

Hack: Control Flow

❖ Startup

- Hack instructions loaded into ROM
- Reset signal initializes computer state (**instruction 0**)

❖ Execution

- Usually, **advance to next** instruction each cycle
- On jump instruction, **write a different address** into the PC

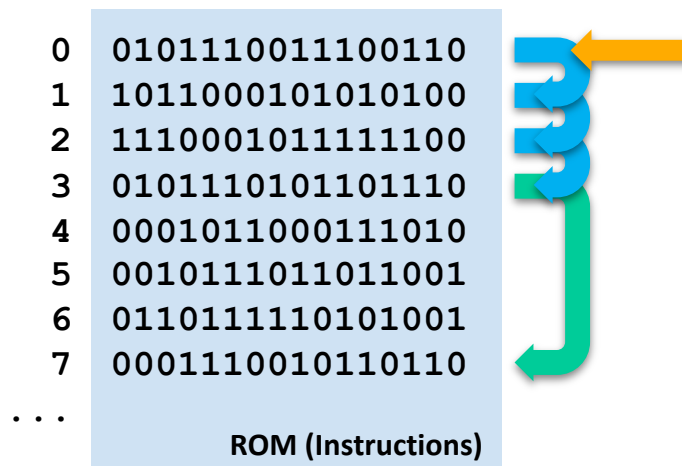

Hack: Registers

- ❖ D Register: For storing Data
- ❖ A Register: For storing data *and* Addressing memory
- ❖ M “Register”: The 16-bit word in Memory currently being referenced by the address in A

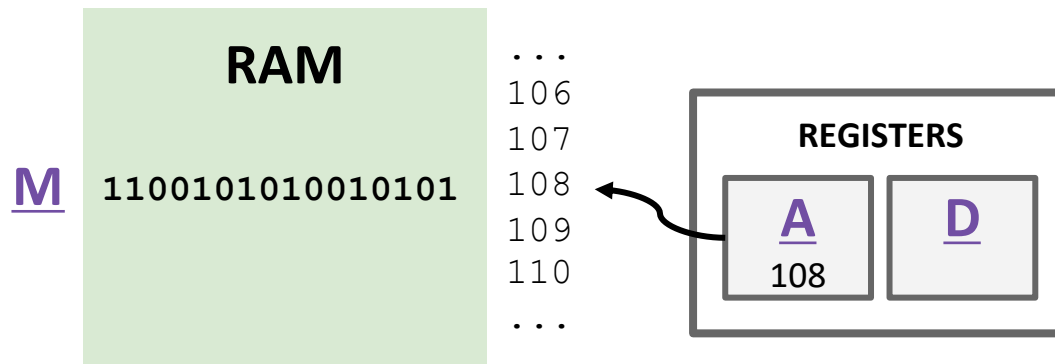

Hack: A-Instructions

- ❖ Syntax: `@value`
- ❖ **value** can either be:
 - A decimal constant
 - A symbol referring to a constant
- ❖ Semantics:
 - Stores **value** in the A register

Hack: A-Instructions

❖ Symbolic Syntax

@value

- Loads a value into the A register

❖ Example:

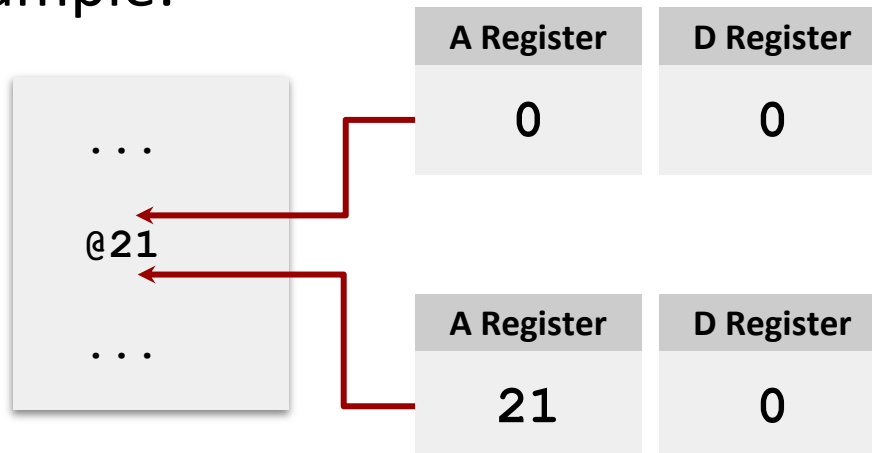

❖ Binary Syntax

00000000000010101

Family:
A-Instruction

Value:
Binary
encoding of 21

Hack: Symbols

- ❖ Symbols are simply an alias for some address
 - Only in the symbolic code—don't turn into a binary instruction
 - Assembler converts use of that symbol to its value instead

- ❖ Example:

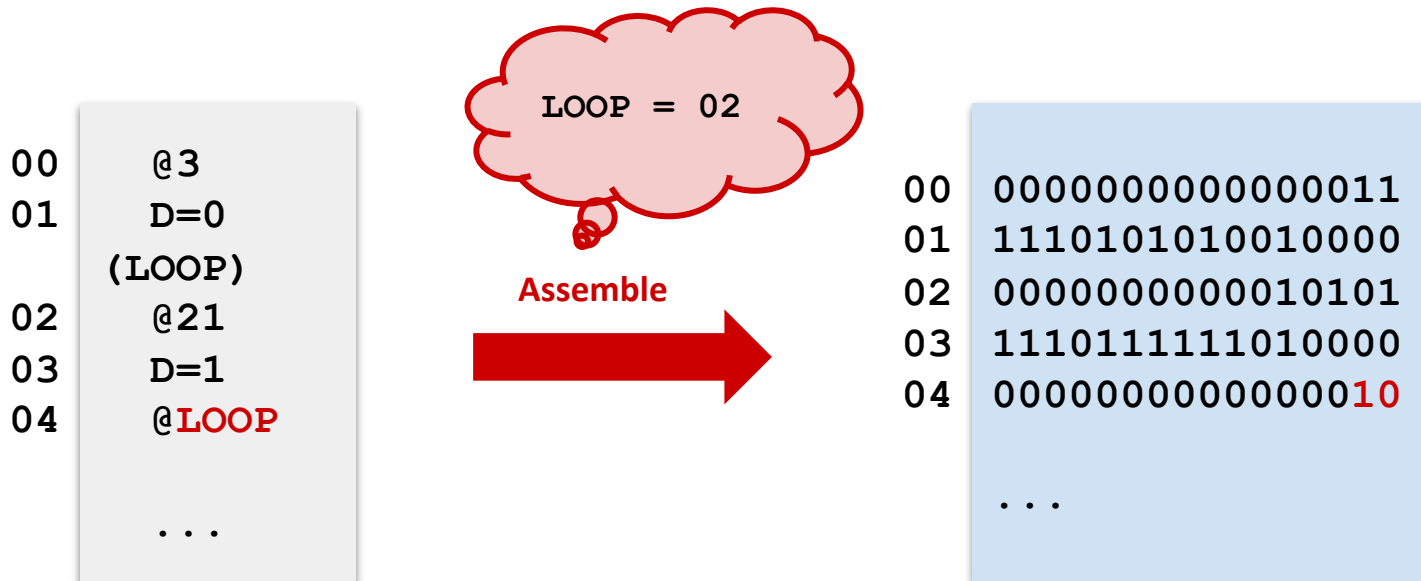

Hack: Built-In Symbols

- ❖ Using () defines a symbol in ROM / Instructions
- ❖ Assembler knows a few built-in symbols in RAM / Data
- ❖ **R0**, **R1**, . . . , **R15**: Correspond to addresses at the very beginning of RAM (0, 1, ..., 15)
 - “Virtual registers,” Useful to store variables
- ❖ **SCREEN**, **KBD**: Base of I/O Memory Maps
- ❖ Example:

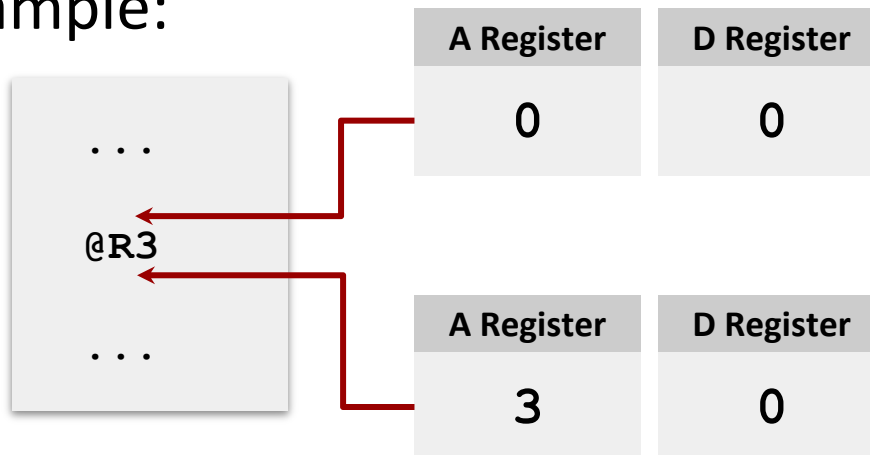

Hack: C-Instructions

❖ Syntax: `dest = comp ; jump` (**dest** and **jump** optional)

- **dest** is a combination of destination registers:

`M, D, MD, A, AM, AD, AMD`

- **comp** is a computation:

`0, 1, -1, D, A, !D, !A, -D, -A, D+1, A+1, D-1, A-1, D+A, D-A, A-D, D&A, D|A, M, !M, -M, M+1, M-1, D+M, D-M, M-D, D&M, D|M`

- **jump** is an unconditional or conditional jump:

`JGT, JEQ, JGE, JLT, JNE, JLE, JMP`

❖ Semantics:

- Computes value of **comp**
- Stores results in **dest** (if specified)
- If **jump** is specified and condition is true (by testing **comp** result), jump to instruction **ROM[A]**

Hack: C-Instructions Example

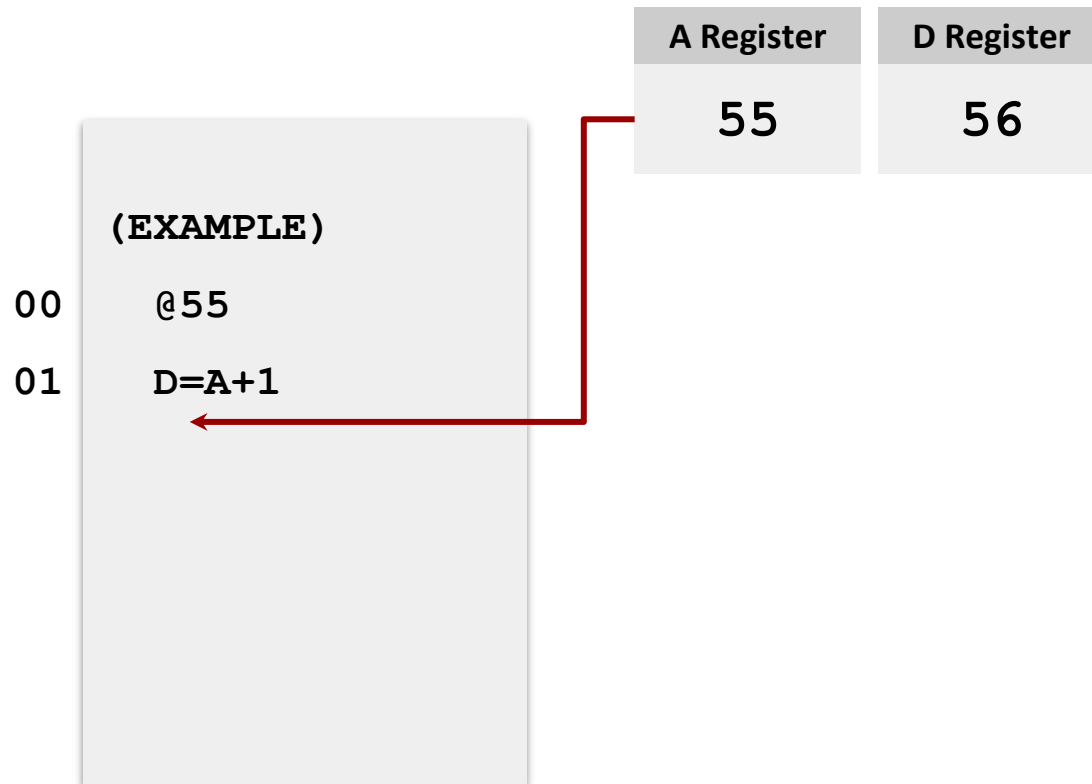

Hack: C-Instructions Example

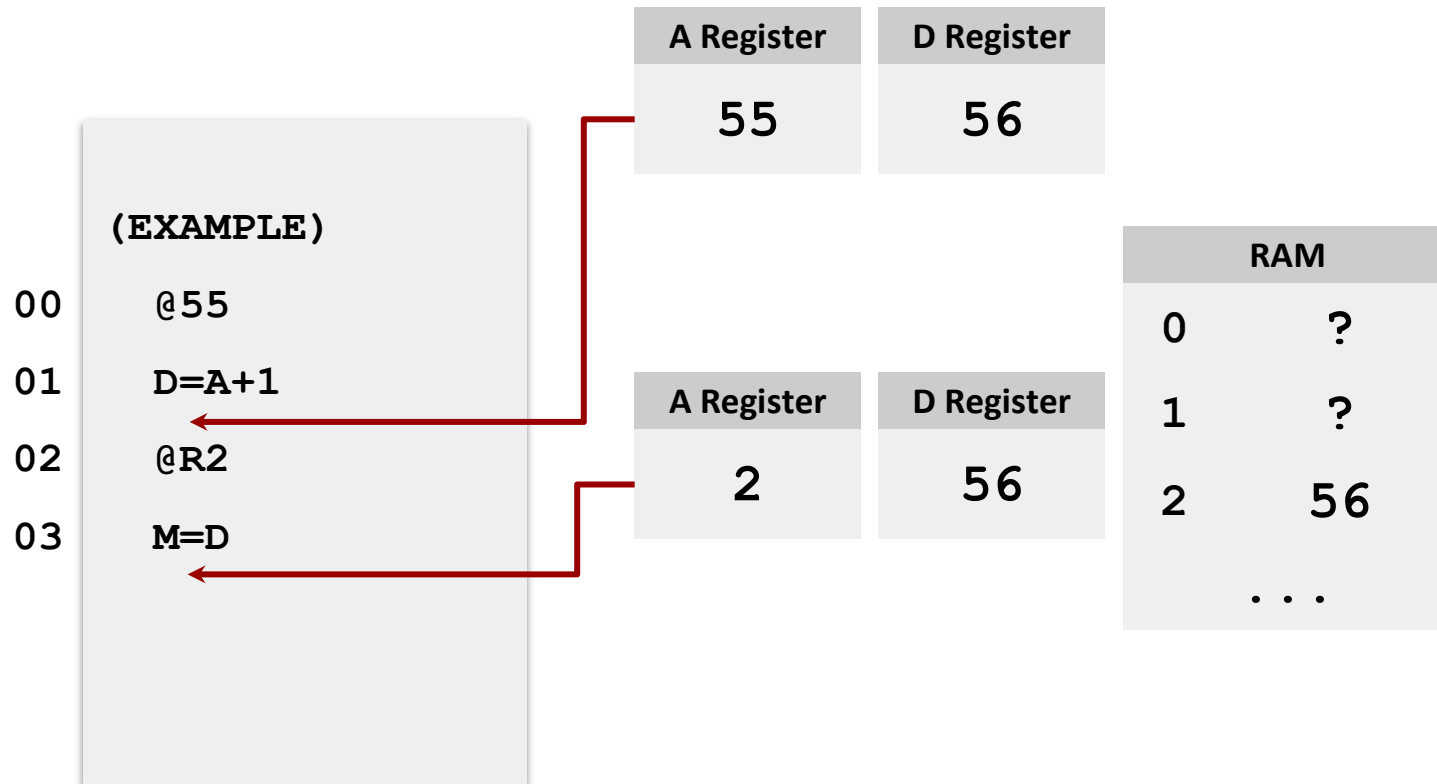

Hack: C-Instructions Example

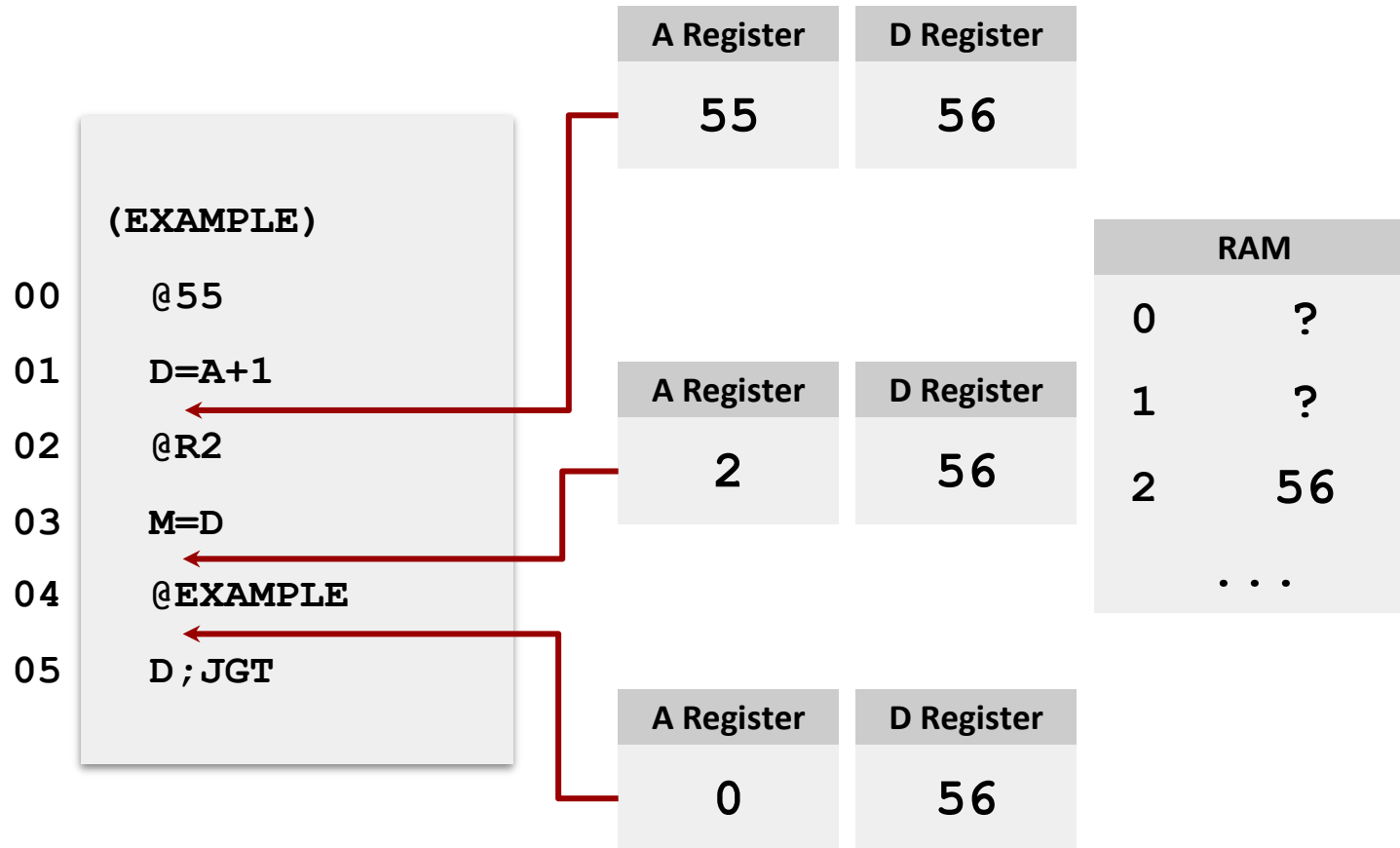

(Will jump to instruction 0, since $D > 0$)

Hack: C-Instructions

❖ Symbolic: `dest = comp ; jump`

❖ Binary: `1 1 1 a c1 c2 c3 c4 c5 c6 d1 d2 d3 j1 j2 j3`

Family:
C-Instruction

Unused

Comp:
ALU Operation (a bit chooses
between A and M)

Dest:
Where to store
result

Jump:
Condition for
jumping

Hack: C-Instructions

❖ Symbolic: `dest = comp ; jump`

❖ Binary: `1 1 1 a c1 c2 c3 c4 c5 c6 d1 d2 d3 j1 j2 j3`

Jump:
Condition for
jumping

Chapter 4

j1 (<i>out</i> < 0)	j2 (<i>out</i> = 0)	j3 (<i>out</i> > 0)	Mnemonic	Effect
0	0	0	null	No jump
0	0	1	JGT	If <i>out</i> > 0 jump
0	1	0	JEQ	If <i>out</i> = 0 jump
0	1	1	JGE	If <i>out</i> ≥ 0 jump
1	0	0	JLT	If <i>out</i> < 0 jump
1	0	1	JNE	If <i>out</i> ≠ 0 jump
1	1	0	JLE	If <i>out</i> ≤ 0 jump
1	1	1	JMP	Jump

Hack: C-Instructions

❖ Symbolic: `dest = comp ; jump`

❖ Binary: `1 1 1 a c1 c2 c3 c4 c5 c6 d1 d2 d3 j1 j2 j3`

Dest:
Where to store
result

d1	d2	d3	Mnemonic	Destination (where to store the computed value)
0	0	0	null	The value is not stored anywhere
0	0	1	M	Memory[A] (memory register addressed by A)
0	1	0	D	D register
0	1	1	MD	Memory[A] and D register
1	0	0	A	A register
1	0	1	AM	A register and Memory[A]
1	1	0	AD	A register and D register
1	1	1	AMD	A register, Memory[A], and D register

Chapter 4

Hack: C-Instructions

❖ Symbolic: `dest = comp ; jump`

❖ Binary: `1 1 1 a c1 c2 c3 c4 c5 c6 d1 d2 d3 j1 j2 j3`

(when a=0) <i>comp mnemonic</i>	c1	c2	c3	c4	c5	c6	(when a=1) <i>comp mnemonic</i>
0	1	0	1	0	1	0	
1	1	1	1	1	1	1	
-1	1	1	1	0	1	0	
D	0	0	1	1	0	0	
A	1	1	0	0	0	0	M
!D	0	0	1	1	0	1	
!A	1	1	0	0	0	1	!M
-D	0	0	1	1	1	1	
-A	1	1	0	0	1	1	-M
D+1	0	1	1	1	1	1	M+1
A+1	1	1	0	1	1	1	
D-1	0	0	1	1	1	0	
A-1	1	1	0	0	1	0	M-1
D+A	0	0	0	0	1	0	D+M
D-A	0	1	0	0	1	1	D-M
A-D	0	0	0	1	1	1	M-D
D&A	0	0	0	0	0	0	D&M
D A	0	1	0	1	0	1	D M

Comp:
ALU Operation (a bit chooses between A and M)

Chapter 4

Important: just pattern matching text!

Cannot have "1+M"

< Lecture 8: Annotation Strategies & Hack Assembly



🌐 When poll is active, respond at **PolleV.com/cse390b**

What is the C-instruction encoding for D;JGE?

1 1 1 1 1 0 0 1 1 1 0 0 1 0 0 1

1 1 1 0 0 0 1 1 0 0 0 0 0 0 1 1

1 1 1 0 1 0 0 1 1 1 0 1 0 0 1 0

1 1 1 1 0 0 1 1 0 0 0 0 0 0 1 1

We're lost...

Total Results: 0

Powered by  **Poll Everywhere**





Vote at <https://pollev.com/cse390b>

What is the C-instruction encoding for D ; JGE?

j1 (out < 0)	j2 (out = 0)	j3 (out > 0)	Mnemonic	Effect
0	0	0	null	No jump
0	0	1	JGT	If out > 0 jump
0	1	0	JEQ	If out = 0 jump
0	1	1	JGE	If out ≥ 0 jump
1	0	0	JLT	If out < 0 jump
1	0	1	JNE	If out ≠ 0 jump
1	1	0	JLE	If out ≤ 0 jump
1	1	1	JMP	Jump

(when a=0) comp mnemonic	c1	c2	c3	c4	c5	c6	(when a=1) comp mnemonic
0	1	0	1	0	1	0	
1	1	1	1	1	1	1	
-1	1	1	1	0	1	0	
D	0	0	1	1	0	0	
A	1	1	0	0	0	0	M
!D	0	0	1	1	0	1	
!A	1	1	0	0	0	1	!M
-D	0	0	1	1	1	1	
-A	1	1	0	0	1	1	-M
D+1	0	1	1	1	1	1	
A+1	1	1	0	1	1	1	M+1
D-1	0	0	1	1	1	0	
A-1	1	1	0	0	1	0	M-1
D+A	0	0	0	0	1	0	D+M
D-A	0	1	0	0	1	1	D-M
A-D	0	0	0	1	1	1	M-D
D&A	0	0	0	0	0	0	D&M
D A	0	1	0	1	0	1	D M

d1	d2	d3	Mnemonic	Destination (where to store the computed value)
0	0	0	null	The value is not stored anywhere
0	0	1	M	Memory[A] (memory register addressed by A)
0	1	0	D	D register
0	1	1	MD	Memory[A] and D register
1	0	0	A	A register
1	0	1	AM	A register and Memory[A]
1	1	0	AD	A register and D register
1	1	1	AMD	A register, Memory[A], and D register

Lecture Outline

- ❖ Strategies for Annotating Texts
 - Motivation and Techniques for Annotation
- ❖ Hack Assembly Memory Representation
 - I/O, Memory Mapping, External vs. Internal Memory
- ❖ Hack Assembly Language Review
 - Registers, A-Instructions, Symbols, & C-Instructions
- ❖ **Multiplication Implementation Exercise**
 - **Multiplying Two Numbers in Hack Assembly**

Exercise: Implementing Multiplication

- ❖ Write a program that multiplies **R0** and **R1** and stores the result in **R2**
 - Remember we don't have a multiply operation
 - We will have to use add and loops to get the job done

- ❖ Roadmap
 - Start with pseudocode using if statements, loops, etc.
 - Remove conditionals and loops by using jumps in pseudocode
 - Convert pseudocode to assembly

Exercise: Implementing Multiplication

❖ Goal: Implement $R0 \times R1 = R2$

Pseudocode	Hack Assembly

Exercise: Implementing Multiplication

❖ Goal: Implement $R0 \times R1 = R2$

Pseudocode	Hack Assembly
<p>❖ Approach: add R0 to the result R1 times</p>	

Exercise: Implementing Multiplication

❖ Goal: Implement $R0 \times R1 = R2$

Pseudocode

Hack Assembly

❖ Approach: add **R0** to the result **R1** times

```
R2 = 0
while (R1 > 0) {
    R2 = R0 + R2
    R1 = R1 - 1
}
```

Exercise: Implementing Multiplication

- ❖ Remove loops from pseudocode
- ❖ Use labels to notate important sections of the code

```
R2 = 0
while (R1 > 0) {
    R2 = R0 + R2
    R1 = R1 - 1
}
```



- ❖ Attempt 1: What happens when **R1** is 0? What should happen?

START:

```
R2 = 0
```

LOOP:

```
R2 = R0 + R2
```

```
R1 = R1 - 1
```

```
IF R1 > 0 JMP LOOP
```

END:

```
INFINITE LOOP
```

Exercise: Implementing Multiplication

- ❖ Remove loops from pseudocode
- ❖ Use labels to notate important sections of the code

```
R2 = 0
while (R1 > 0) {
    R2 = R0 + R2
    R1 = R1 - 1
}
```



- ❖ Attempt 1: What happens when **R1** is 0? What should happen?

START:

R2 = 0

LOOP:

IF R1 <= 0

JMP to END

R2 = R0 + R2

R1 = R1 - 1

JMP LOOP

END:

INFINITE LOOP

Exercise: Implementing Multiplication

❖ Convert to Hack Assembly

START:

R2 = 0

LOOP:

IF R1 <= 0

JMP to END

R2 = R0 + R2

R1 = R1 - 1

JMP LOOP

END:

INFINITE LOOP



(START)

@R2

M = 0

(LOOP)

(END)

Exercise: Implementing Multiplication

❖ Convert to Hack Assembly

START:

R2 = 0

LOOP:

IF R1 <= 0

JMP to END

R2 = R0 + R2

R1 = R1 - 1

JMP LOOP

END:

INFINITE LOOP



(START)

@R2

M = 0

(LOOP)

@R1

D = A

@END

D; JLE

(END)

Exercise: Implementing Multiplication

❖ Convert to Hack Assembly

START:

R2 = 0

LOOP:

IF R1 <= 0

JMP to END

R2 = R0 + R2

R1 = R1 - 1

JMP LOOP

END:

INFINITE LOOP



(START)

@R2

M = 0

(LOOP)

@R1

D = M

@END

D; JLE

(END)

Exercise: Implementing Multiplication

❖ Convert to Hack Assembly

```
START:
    R2 = 0
LOOP:
    IF R1 <= 0
        JMP to END
    R2 = R0 + R2
    R1 = R1 - 1
    JMP LOOP
END:
    INFINITE LOOP
```



```
(START)
    @R2
    M = 0
(LLOOP)
    @R1
    D = M
    @END
    D; JLE
    @R0
    D = M
    @R2
    M = M + D
(END)
```

Exercise: Implementing Multiplication

❖ Convert to Hack Assembly

```
START:
    R2 = 0
LOOP:
    IF R1 <= 0
        JMP to END
    R2 = R0 + R2
    R1 = R1 - 1
    JMP LOOP
END:
    INFINITE LOOP
```



```
(START)
    @R2
    M = 0
(LLOOP)
    @R1
    D = M
    @END
    D; JLE
    @R0
    D = M
    @R2
    M = M + D
    @R1
    M = M - 1
    @LLOOP
    0; JMP
(END)
```

Exercise: Implementing Multiplication

❖ Convert to Hack Assembly

```
START:
    R2 = 0
LOOP:
    IF R1 <= 0
        JMP to END
    R2 = R0 + R2
    R1 = R1 - 1
    JMP LOOP
END:
    INFINITE LOOP
```



```
(START)
    @R2
    M = 0
(LOOP)
    @R1
    D = M
    @END
    D; JLE
    @R0
    D = M
    @R2
    M = M + D
    @R1
    M = M - 1
    @LOOP
    0; JMP
(END)
    @END
    0; JMP
```

Lecture Outline

- ❖ Hack Assembly Memory Representation
 - I/O, Memory Mapping, External vs. Internal Memory
- ❖ Hack Assembly Language Review
 - Registers, A-Instructions, Symbols, & C-Instructions
- ❖ Multiplication Implementation Exercise
 - Multiplying Two Numbers in Hack Assembly
- ❖ **Project 5 Overview**
 - **Specification Annotation, Machine Language, & Building Computer Memory**

Project 5 Overview

- ❖ Part I: Annotation
 - Come prepared to your upcoming Student-TA 1:1 meeting to work on Project 5 (e.g., specification reading and identifying annotation strategies you would want to use)

- ❖ Part II: Machine Language
 - Implement Max.asm in Hack Assembly

- ❖ Part III: Building Computer Memory
 - Implement Memory.hdl in HDL

- ❖ Part IV: Project 5 Reflection

Project 5, Part I: Annotation

❖ Fill out the Assignment Timeline

- Divide up Project 5 into doable chunks for the days you plan to work on the assignment
- Describe each day's task in as much detail as possible

❖ Annotate the Project 5 Specification

- Identify five annotation strategies that you want to try
- Practice these strategies on the Project 5 specification

❖ Complete Annotation Reflection Questions

- Reflect on the strategies you used and why or why not they were effective

Annotate the Project 5 Specification

- ❖ We'll provide you with an opportunity to start annotating the Project 5 specification in class now
- ❖ Recall these annotation strategies:
 - **Highlighting**, underlining or using [brackets] to note key points or ideas
 - Circling unfamiliar words or confusing parts of the text
 - Paraphrasing or summarizing passages/chapters/sections
 - **Commenting or reacting to the text** 🤖

Project 5: Tools

❖ Running a Test Script (recommended flow):

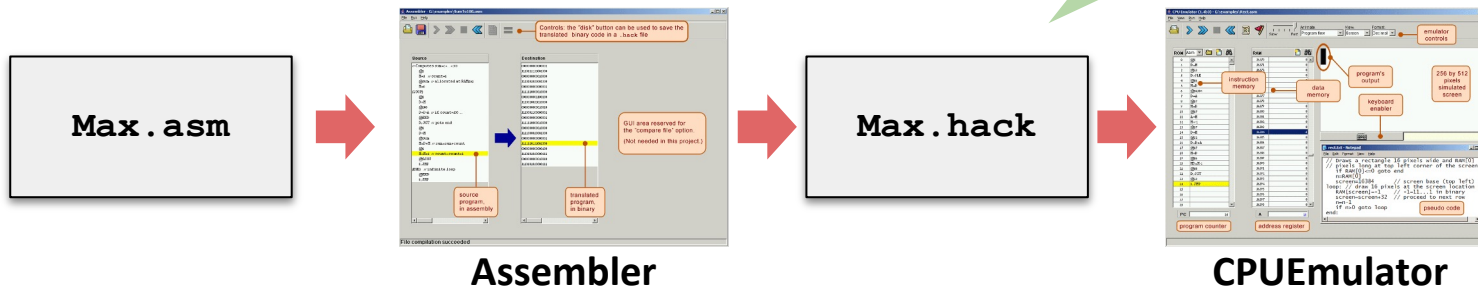

The test scripts use the .hack files directly! Don't let your .asm and .hack get out of sync!

❖ Quickly Iterating or Experimenting:

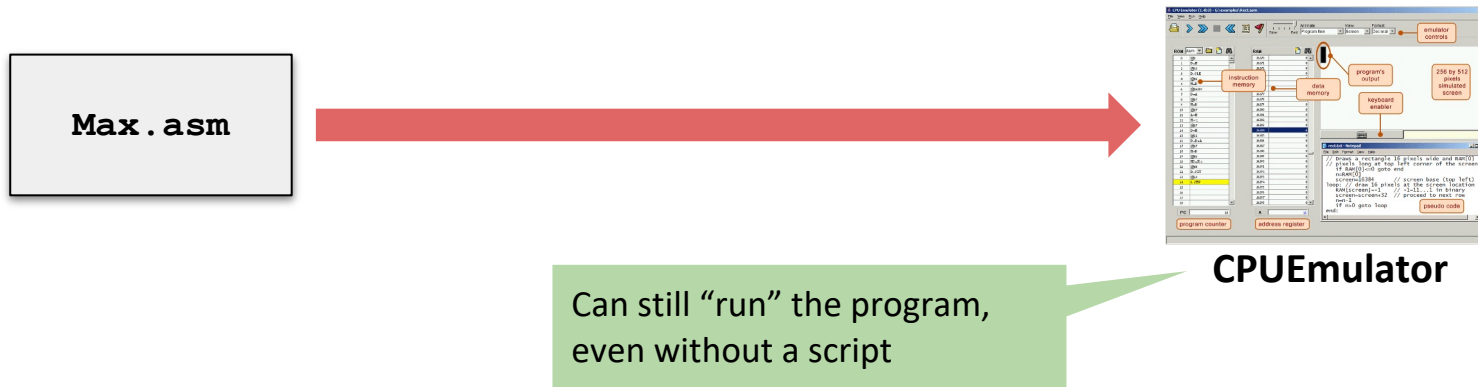

Lecture 8 Reminders

- ❖ **Project 4 due tonight (1/26) at 11:59pm**
- ❖ Project 5 (Annotation, Machine Language, & Building Computer Memory) released today, due next Thursday (2/2) at 11:59pm
- ❖ Eric has office hours after class in CSE2 153
 - Feel free to post your questions on the Ed board as well